

A-Series

COMPRESSOR AND VACUUM BARES FOR AIR AND NATURAL GAS
5-40 HP

- ▶ Bulk Material Handling
- ▶ Well Head Servicing
- ▶ Engine Starting
- ▶ Petroleum Refineries
- ▶ Offshore Platforms
- ▶ Natural Gas Gathering

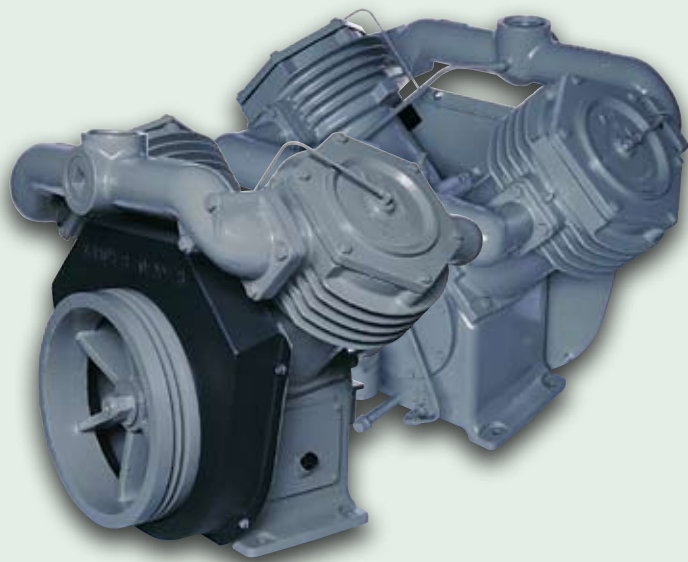

CHAMPION[®]

A-Series Bares

The A-Series reputation has been built on quality, reliability and accessibility to all components.

The Champion APL and APO are single stage, two cylinder, pressure lubricated compressors equipped with a two-groove, 17 inch sheave for belt driven applications. The APL and APO have an integrated cooling fan built into the cast iron sheave for maximum cooling.

The Champion ATLE6-CH is a single stage, two cylinder, pressure lubricated compressor that is equipped with an SAE#3 bell housing flange for direct engine mounting and remote site operation.

Wherever there's a demand for a low pressure engine driven compressor, the ATLE6-CH is the compressor for the job. Because it is direct coupled to the engine, there is no need to worry about belts slipping or wearing out. When connected to the engine, all rotating components are totally enclosed and protected from the environment.

The AVLEK is a single stage vacuum pump, AVLAN is a single stage booster and the AVLAV is a two-stage compressor. All A-Series compressors are designed to provide optimum performance in a wide variety of operations.

The ANP is ideal for natural gas gathering applications and is available in both single- and two-stage models.

Lubrication

- ▶ Superior lubrication is accomplished through a gear driven oil pump powered by the crankshaft.
- ▶ Pressurized system ensures complete lubrication to the crankshaft, connecting rods, bearings and piston pins.
- ▶ Full flow, spin-on oil filter ensures impurities are removed before the lubricant contacts any internal components.
- ▶ Oil pressure gauge is conveniently mounted to display the oil pressure.

Valves

- ▶ Concentric ring design incorporates both the inlet and outlet valves in one assembly.
- ▶ Designed to give 100% exposure to the air flow for maximum efficiency (i.e. more CFM per HP).
- ▶ Discs and springs are made of AISI 420 stainless steel to give dependable corrosion-free and fatigue-free service life.

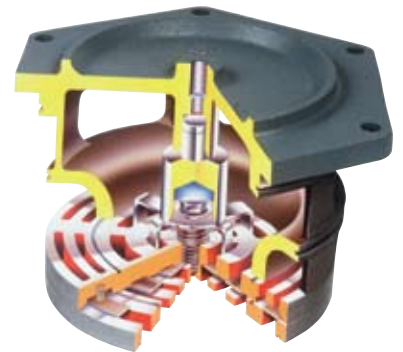

Standard Features

1. ASME **pressure relief valve** protects the intercooler and first stage from over pressure.
2. **Suction unloading valves** (where applicable) provide loadless starting and stopping as well as quick response to capacity demands.
3. Removable **hand-hole plate** allows easy access to the internal running gear.
4. Tri-Metal **insert bearings** are two-piece for quick and easy replacement.
5. Counterbalanced **crankshaft** assures smooth operation.
6. Replaceable **piston pin bearings** are very economical when replacement becomes necessary.
7. Generously sized **intercooler** provides maximum cooling for the most efficient operation and low power consumption. (AVLAVCAA-CH only)
8. Deep-finned **cylinders** and heads quickly dissipate the heat of compression.
9. Crankshaft ends are supported by large **tapered roller bearings** for smooth operation and long life.
10. **Oil pressure gauge** assures the operator of lubrication system integrity.
11. The **cylinders and crankcase** are built of industrial strength cast iron materials.

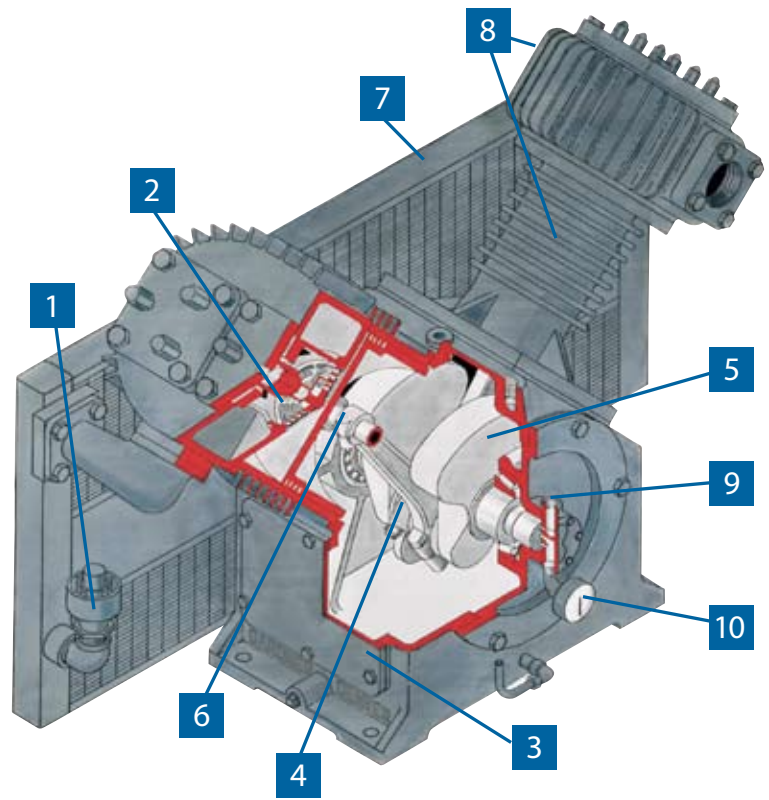

A-Series Bares

Compressor designs optimized for premium service in the following applications:

- ▶ Bulk Material Handling
- ▶ Engine Starting
- ▶ Well Head Servicing
- ▶ Petroleum Refineries
- ▶ Industrial Spraying

28" HG-60 PSIG
(0.95–4.1 Bar G)

Continuous
Operation

5–30 HP
(3.7–22.4 kW)



**APLGAA-CH, APLGBA-CH,
APLHAA-CH, APLHBA-CH**

Single Stage Compressor

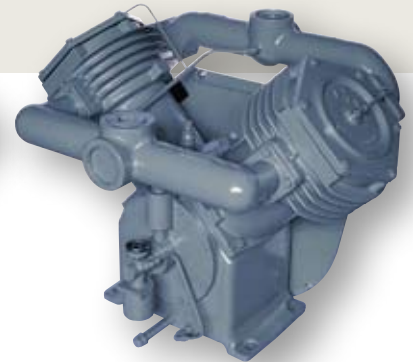

**APOGAA-CH, APOGBA-CH,
APOHAA-CH, APOHBA-CH**

Single Stage Compressor

DIMENSIONS

Model	Bore Diameter		Stroke	Suction & Discharge Pipe Size NPT	Dimensions L x W x H	Weight	
	in	mm				lbs	kg
APL	in	7.875/7.875	3	3	41 x 29 x 30	lbs	750
	mm	200	76	NA	1041 x 737 x 762	kg	340
APO	in	7.875/7.875	4.5	3	41 x 29 x 30	lbs	750
	mm	200	114	NA	1041 x 737 x 762	kg	340

COMPRESSOR SPECIFICATIONS

Model	Speed hp/kw	Pressure		Capacity	
		psig	barg	cfm	m ³ /min
APL	855 15/11.2	20	1.4	113	3.2
		30	2.1	105	3.0
		40	2.8	98	2.8
		50	3.4	90	2.5
		60	4.1	83	3.1
APO	698 20/14.9	20	1.4	145	4.1
		30	2.1	134	3.8
		40	2.8	125	3.5
		50	3.4	117	3.3
APO	885 25/18.6	20	1.4	181	5.1
		30	2.1	169	4.8
		40	2.8	158	4.5
		50	3.4	148	4.2
		60	4.1	138	3.9
APO	1072 30/22.4	20	1.4	218	6.1
		30	2.1	205	5.8
		40	2.8	192	5.4
		50	3.4	180	5.1
		60	4.1	168	4.8

VACUUM SPECIFICATIONS

Model	Speed hp/kw	Capacity		Vac. - HG	
		cfm	m ³ /min	in	mm
APL	780 5/3.7	120	3.4	5	127
		114	3.2	10	254
		105	3.0	15	381
		92	2.6	20	508
		60	1.7	25	635
		NA	NA	28	711
APO	739 7.5/5.6	167	4.7	5	127
		164	4.6	10	254
		157	4.4	15	381
		145	4.1	20	508
		99	2.8	25	635
APO	937 10/7.5	NA	NA	28	711
		198	5.6	5	127
		193	5.5	10	254
		185	5.2	15	381
		169	4.8	20	508
		117	3.5	25	635
APO	937 10/7.5	NA	NA	28	711

A-Series Bares

ATLE6-CH

Single Stage Compressor

- ▶ Pressure Lubricated
- ▶ Single-Stage, 2 Cylinders
- ▶ SAE #3 Bell Housing
- ▶ Low Pressure Bare
- ▶ Factory Fill with ChampLub 500



ATLE6-CH DIMENSIONS

Model	Bore Diameter		Stroke	Suction & Discharge Pipe Size NPT		Dimensions L x W x H		Weight	
ATLE6	in	7.875	3	3		41 x 29 x 30		lbs 750	
	mm	200	76	NA		1041 x 737 x 762		kg 340	

ATLE6-CH SPECIFICATIONS

Speed rpm	Piston Displacement		Oil Capacity		Maximum Pressure		@ 30 psig – 2.07 bars						
							Discharge Air Temp		Duty Cycle	Flow		BHP	
	cfm	m ³ /min	quarts	liters	psig	barg	°F	°C		cfm	m ³ /min	hp	kw
1550	262	7.8	9	8.5	30	2.07	400	204	intermittent	180	5.1	29	22



A-Series Bares



AVLEKCAA-CH
Single Stage Vacuum Pump



AVLANCAA-CH
Single Stage Booster



AVLAVCAA-CH
Two Stage Compressor

25" HG-350 PSIG (6.9–17.24 Bar G) Continuous Operation 7.5-40 HP (5.6–30 kW)

DIMENSIONS

- ▶ Single-Stage Vacuum and Booster Bare
- ▶ Two-Stage Air Compressor Bare
- ▶ Pressure Lubricated
- ▶ Factory Fill with ChampLub 500
- ▶ Cast Iron Construction

Model	Bore Diameter	Stroke	Suction & Discharge Pipe Size NPT	Discharge	Dimensions L x W x H	Weight
AVLAVCAA-CH	in 8.00/4.25	4.50	3	2	40 x 27 x 33	lbs 680
	mm 203/108	114	NA	NA	1016 x 686 x 838	kg 308
AVLANCAA-CH	in 4.25/4.25	4.50	2	2	38 x 27 x 33	lbs 600
	mm 108	114	NA	NA	965 x 686 x 838	kg 272
AVLEKCAA-CH	in 7.50/7.50	4.50	3	3	38 x 27 x 33	lbs 600
	mm 191	114	NA	NA	965 x 686 x 838	kg 272

COMPRESSOR SPECIFICATIONS

HP kW	Speed	Pressure		Capacity	
		psig	bars	cfm	m ³ /min
AVLAVCAA-CH					
25 19	968	100	6.90	101	2.86
	922	125	8.62	96.5	2.73
	830	175	12.07	85	2.41
	784	250	17.24	78	2.21
30 22	1106	100	6.90	116	3.29
	1014	125	8.62	105	2.97
	968	175	12.07	99	2.80
	876	250	17.24	87	2.46
AVLANCAA-CH					
40 30	Suction Pressures: 1–140 psig Discharge Pressure: up to 350 psig Consult factory for sizing and technical information.				

VACUUM SPECIFICATIONS

HP kW	Speed	Capacity		Vac. - HG	
		cfm	m ³ /min	in	mm
AVLEKCAA-CH					
7.5–10 5.6–7.5	870	169	4.79	5	127
	870	160	4.53	10	254
	870	146	4.13	15	381
	870	122	3.46	20	508
	870	62	1.75	25	635

A-Series Natural Gas Bares



ANPEAA-CH



ANPHAA-CH

ANPEAA-CH, ANPHAA-CH

Ideal for use in natural gas gathering applications

- ▶ Concentric Ring Type Valves
- ▶ AISI 420 Stainless Steel Discs and Springs
- ▶ Drive Sheave with Turbo Fins
- ▶ Viton O-Rings
- ▶ Threaded Crankcase Vent Connection
- ▶ Counter Balanced Crankshaft
- ▶ Cast Iron Construction
- ▶ Factory Fill with ChampLub 500

COMPRESSOR SPECIFICATIONS

Description	ANPHAA-CH	ANPEAA-CH
Compressor HP Range	40 Max	40 Max
Rotation (drive end)	Clockwise	Clockwise
Valves	Plain	Plain
Bore & Stroke (inches)	7 ⁷ / ₈ & 7 ⁷ / ₈ x 4 ¹ / ₂	4 ¹ / ₄ & 4 ¹ / ₄ x 4 ¹ / ₂
Speed Range (RPM)	550-1000	550-1000
Number Cylinders	2	2
Weight (pounds)	750	600
Dimensions (inches)	L 40.3 W 28.78 H 29.9	L 33.9 W 24.34 H 26.8
Maximum Pressure	60 PSIG	250 PSIG

ANPHAA Performance @ 968 RPM

MSCFD		DISCHARGE PSIG										
		10	15	20	25	30	35	40	45	50	55	60
SUCTION PSIG	-10	70.4	66.3	62.3	58.5	150.7	146.5	142.3	138.2	134.2	130.2	126.3
	-5	180.1	172.7	165.5	158.4	150.7	146.5	142.3	138.2	134.2	130.2	126.3
	0	292.7	284.8	277.2	269.6	262.3	255.0	247.9	240.8	233.8	226.8	222.5
	5	406.0	397.8	389.8	381.9	374.2	366.6	359.2	351.8	344.5	337.3	330.2
	10		511.3	502.9	494.8	486.8	479.0	471.3	463.7	456.1	448.7	441.3
	15				608.1	599.9	591.9	583.9	576.1	568.3	560.7	553.1
	20					713.3	705.0	696.9	688.9	681.0	673.2	665.4
	25						818.5	810.2	802.0	793.9	786.0	778.1
	30							923.7	915.4	907.2	899.0	891.0
	35								1028.9	1020.6	1012.3	1004.1
	40										1125.8	1117.5
45											1231.0	

BHP		DISCHARGE PSIG										
		10	15	20	25	30	35	40	45	50	55	60
SUCTION PSIG	-10	9.1	10.1	11.1	12.0	17.3	18.4	19.5	20.5	21.5	22.5	23.4
	-5	12.7	14.3	15.5	16.5	17.3	18.4	19.5	20.5	21.5	22.5	23.4
	0	12.5	15.5	18.0	20.0	21.6	22.9	24.0	25.0	25.9	26.7	27.8
	5	10.4	14.5	17.8	20.7	23.3	25.5	27.3	28.9	30.2	31.3	32.4
	10		11.7	16.2	19.8	23.0	25.9	28.5	30.9	32.9	34.6	36.1
	15				17.9	21.7	25.1	28.2	31.1	33.8	36.2	38.3
	20					19.4	23.5	27.0	30.3	33.4	36.3	39.0
	25						20.9	25.2	28.9	32.3	35.5	38.6
	30							22.2	26.8	30.7	34.3	37.6
	35								23.4	28.4	32.5	36.1
	40										29.8	34.1
45											31.2	

Note: Sweet Natural Gas with N Value of 1.3; MSCFD = Flow at 14.7 PSIA and 60° F

ANPEAA Performance @ 968 RPM

MSCFD		DISCHARGE PSIG								
		50	75	100	125	150	175	200	225	250
SUCTION PSIG	0	57.6	46.1	36.1						
	10	123.8	108.2	92.8	82.1	71.9	61.9	52.3		
	20	191.3	174.7	158.9	143.7	128.8	118.1	107.8	97.6	87.7
	30	259.3	242.1	225.6	209.7	194.3	179.3	164.9	154.2	143.7
	40		310.0	292.9	276.5	260.6	245.0	229.8	214.9	200.9
	50		378.2	360.7	343.8	327.4	311.4	295.8	280.5	265.4
	60		446.7	428.8	411.5	394.7	378.3	362.3	346.6	331.2
	70			497.1	479.4	462.3	445.6	429.2	413.2	397.5
	80			565.6	547.6	530.1	513.1	496.5	480.1	464.1
	90				616.0	598.2	580.9	564.0	547.4	531.0
	100				684.5	666.5	648.9	631.7	614.8	598.3

BHP		DISCHARGE PSIG								
		50	75	100	125	150	175	200	225	250
SUCTION PSIG	0	6.4	6.8	6.8						
	10	8.9	10.2	10.7	11.2	11.5	11.4	11.0		
	20	9.4	12.4	14.0	14.7	15.1	15.7	16.0	16.1	16.0
	30	8.8	13.0	15.9	17.6	18.5	19.1	19.5	20.0	20.4
	40		12.7	16.6	19.4	21.1	22.3	23.0	23.5	23.9
	50		11.9	16.5	20.1	22.8	24.7	25.9	26.8	27.4
	60		10.1	15.9	20.1	23.6	26.2	28.2	29.5	30.5
	70			14.9	19.7	23.7	27.1	29.7	31.6	33.1
	80			13.1	19.0	23.5	27.3	30.5	33.1	35.1
	90				17.9	22.9	27.1	30.8	34.0	36.5
	100				16.1	22.0	26.7	30.7	34.3	37.4



1301 North Euclid Avenue
 Princeton, Illinois 61356 USA
 Phone 888/436-5499
 Fax 815/872-0421
 E-mail: Champion@championpneumatic.com
www.ChampionPneumatic.com

